

# 1.3MP Network IR Mini Bullet Camera

## IPC2121SR3 Series



## Key Features

### Optics

- Day/night functionality
- Smart IR , up to 30 m (98 ft) IR distance
- Optical glass window with higher light transmittance
- IR anti-reflection window to increase the infrared transmittance
- 3D DNR (Digital Noise Reduction)

### Compression

- H.264/MJPEG
- Triple streams

### Network

- ONVIF Conformance

### Structure

- Wide temperature range: -35°C to 60°C (-31°F to 140°F)
- Wide voltage range of  $\pm 25\%$
- IP66

## Specifications

	IPC2121SR3-PF36	IPC2121SR3-PF60	IPC2121SR3-PF120
<b>Camera</b>			
Sensor	1/3", 1.3 megapixel, progressive scan, CMOS		
Lens	3.6mm@F1.8 Angle of view(H): 76.7°	6.0mm@F1.8 Angle of view(H): 46.9°	12.0mm@F1.8 Angle of view(H): 24.2°
Shutter	Auto/Manual, 1/6~1/8000 s		
Min. Illumination	Colour: 0.06 Lux (F1.4, 50IRE) 0 Lux with IR on		
Day/Night	IR-cut filter with auto switch (ICR)		
IR Range	Up to 30m (98 ft) IR range		
S/N	>50dB		
WDR	Digital		
Noise Reduction	2D/3D		
<b>Video</b>			
Max. Resolution	1280×960		
Video Compression	H.264/MJPEG		
Frame Rate	960P (1280*960): Max. 25 fps; 720P (1280*720): Max. 30 fps; D1 (720*576): Max. 25 fps		
Video Streaming	Triple		
ROI	Supported		
OSD	Up to 8 OSDs		
Motion Detection	Up to 2 areas		
Privacy Mask	Up to 4 areas		
<b>Network</b>			
Protocols	L2TP, IPv4, IGMP, ICMP, ARP, TCP, UDP, DHCP, PPPoE, RTP, RTSP, DNS, DDNS, NTP, FTP, UPnP, HTTP, HTTPS, SMTP, SNMP, SIP, QoS		
Compatible Integration	ONVIF		
<b>Interface</b>			
Network	1 RJ45 10M/100M Base-TX Ethernet		
<b>General</b>			
Power	12 V DC, or PoE (IEEE802.3 af)		
	Power consumption: Max 6.4 W		
Dimensions (L × W × H)	157.3 × 62.4 × 63 mm (6.2" × 2.5" × 2.5")		
Weight	0.45 kg (0.99 lb)		
Working Environment	-35°C ~ +60°C (-31°F ~ 140°F), Humidity ≤ 95% RH(non-condensing)		
Ingress Protection	IP66		

## Dimensions

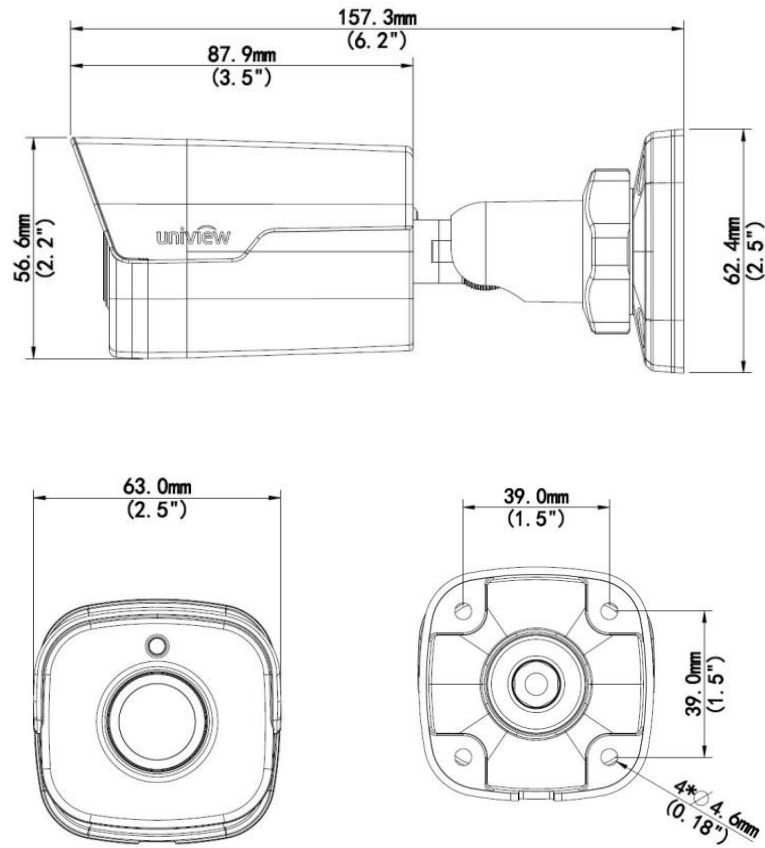

## Accessories

Installation mode	Accessories	Description
Wall mount	Mounting pedestal is included in the Product package	\
Ceiling mount	Mounting pedestal is included in the Product package	\

### Zhejiang Uniview Technologies Co., Ltd.

Building No.10, Wanlun Science Park, Jiangling Road 88, Binjiang District, Hangzhou, Zhejiang, China (310051)

Email: [overseasbusiness@uniview.com](mailto:overseasbusiness@uniview.com); [globalsupport@uniview.com](mailto:globalsupport@uniview.com)

<http://www.uniview.com>

©2015 Zhejiang Uniview Technologies Co., Ltd. All rights reserved.

\*Product specifications and availability are subject to change without notice.